



IT Smontagomme completamente automatico per ruote da camion, autobus, trattori e macchine speciali movimento terra.

EN Fully Automatic tyre changer for trucks, bus, tractors, earth moving and industrial vehicles tyres.

FR Démonte pneus entièrement automatique pour roues de camions, bus, tracteurs agricoles et engins spéciaux de terrassement.

DE Voll-automatische Reifenmontiermaschine für LKW, Busse, Traktoren und spezielle Erdbewegungsmaschinen.

ES Desmontadora de ruedas completamente automática para ruedas de camiones, autobuses, tractores y máquinas especiales de movimiento de tierras.



Caratteristiche • Features • Fonctions • Funktionen • Funciones

56"

IT Bloccaggio cerchi da 14" a 56".
EN Chuck capacity from 14" to 56".
FR Blocage jantes de 14" à 56".
DE Felgenreterierung von 14" bis 56".
ES Bloqueo de llantas de 14" a 56".

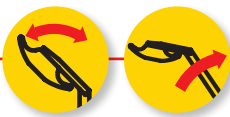

IT Braccio porta utensile con movimentazione del tutto automatizzata (rotazione rapida del disco-utensile e sollevamento del braccio porta utensile).

EN Fully automatic movement of the tool arm (up-and-down movement and fast tool rotation).

FR Les manoeuvres du bras porte-outils sont complètement automatisées (levage du bras et rotation rapide disque-outil).

DE Werkzeugtragearm mit vollautomatischer Bewegung (Heben des Werkzeug und schnelldrehung des Scheibe-Werkzeug).

ES Brazo porta-herramientas con movimientos completamente automatizados (rotación rápida disco-destalonador y elevación del brazo porta-útil).



IT A richiesta disponibile KIT RADIO per la trasmissione dei comandi senza cavo **EN** Available, on request, RADIO KIT control panel for wireless transmission **FR** Sur demande est disponible le KIT RADIO pour la transmission sans câbles **DE** Auf Anfrage ist ein FUNKT KIT zur kabellosen Übertragung der Steuerbefehle erhältlich **ES** Bajo pedido está disponible el KIT RADIO para la transmisión inalámbrica de comandos.



IT Movimento idraulico automatico per la traslazione del carrello **EN** Automatic hydraulic movements for tool-holder carriage translation **FR** Mouvement hydraulique automatique de déplacement du chariot **DE** Automatischer Hydraulikantrieb für das Verfahren des Schlittens **ES** Movimiento hidráulico automático para la traslación del carro.



IT Due velocità di rotazione del mandrino **EN** Chuck with two rotation speed **FR** Deux vitesses de rotation **DE** Zwei Rotationsgeschwindigkeiten der Spannvorrichtung **ES** Dos velocidades de rotación del mandril.

IT Due velocità di rotazione pompa idraulica **EN** Hydraulic pump with two rotation speed **FR** Deux vitesses de rotation pour la pompe hydraulique **DE** Zwei Rotationsgeschwindigkeiten der Hydraulikpumpe **ES** Dos velocidades de rotación de la bomba hidráulica.



IT Pedana di carico ruota collegata al carrello di traslazione **EN** Wheel loading board connect with the tool-holder carriage **FR** Plate forme de charge roues relié au mouvement de déplacement du chariot **DE** An Verfahrensschlitten angeschlossene Rad-Laderampe **ES** Plataforma de carga de la rueda asociada al movimiento de desplazamiento del carro.



IT Funzionamento elettroidraulico **EN** Electro-hydraulic running **FR** Fonctionnement électro-hydraulique **DE** Elektrohydraulischer Betrieb **ES** Funcionamiento electro-hidráulico.

Dotazione Standard • Standard Accessories

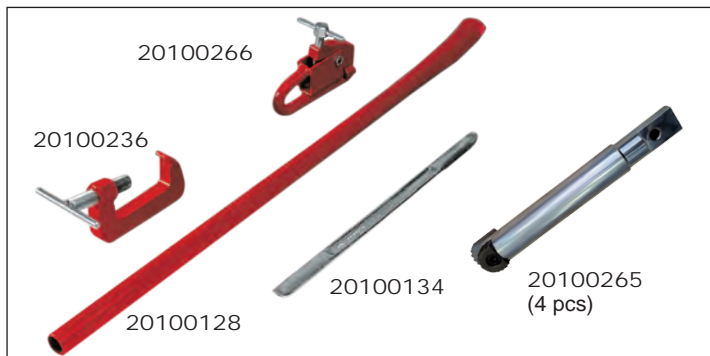

Accessori Opzionali • Optional Accessories

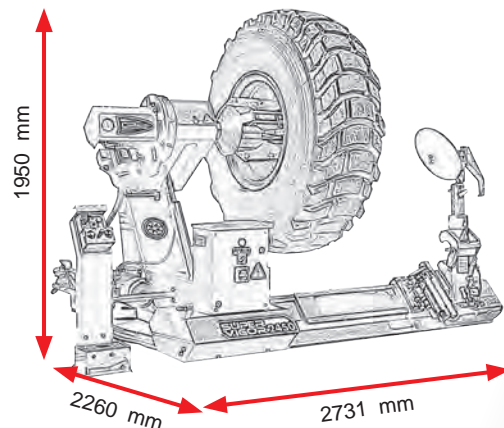
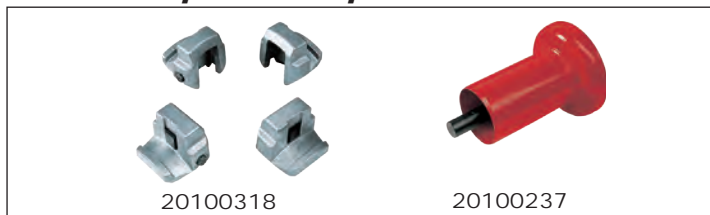

Dati tecnici • Technical data • Données techniques • Technisches Daten • Datos técnicos

• Bloccaggio cerchio • Chuck capacity	• Diametro massimo ruota • Max wheel diameter	• Larghezza massima ruota • Max wheel width	• Peso massimo ruota • Max wheel weight	• Pressione di esercizio • Working pressure	• Alimentazione • Power supply	• Motoriduttore • Gearbox motor	• Motore centralina idraulica • Hydraulic unit motor	• Forza stallonatore • Bead breaker power	• Peso netto • Net weight
• Pour roues de • Aufspannen • Para ruedas de	• Diamètre maximal de la roue • Max. Radaussendurchmesser • Diámetro máx de la rueda	• Largeur maximal de la roue • Max. Reifenbreite • Ancho máx de la rueda	• Poids maximal de la roue • Max. Radgewicht • Peso máximo de la rueda	• Pression de travail • Betriebsdruck • Presión de trabajo	• Alimentation • Stromversorgung • Alimentación	• Moteur réducteur • Getriebemotor • Motor reductor	• Moteur central hydraulique • Hydraulikeinheit-motor • Motor centralita hidráulica	• Force décolleur • Abdrückerkraft • Fuerza destalonador	• Poids net • Nettogewicht • Peso neto
14" - 56"	2450 mm (96")	1220 mm (48")	1300 Kg	0 - 130 bar	230V 3ph 2Speed 400V 3ph 2Speed	230V 3ph 1,25 - 1,8 Kw 400V 3ph 1,25 - 1,8 Kw	230V 3ph 1,25 - 1,8 Kw 400V 3ph 1,25 - 1,8 Kw	3500 Kg	1120 Kg